

# Determination of the Sound Power of a Machine inside an Industrial Room by the Inversion Method

Janusz PIECHOWICZ

*AGH University of Science and Technology*  
*Department of Mechanics and Vibroacoustics*  
Al. Mickiewicza 30, 30-059 Kraków, Poland  
e-mail: piechowi@uci.agh.edu.pl

*(received March 15, 2008; accepted April 24, 2009)*

Utilisation of the substitute sources system consisting of monopole sound sources is one of the methods of sound sources modelling in the industry. The knowledge of the actual acoustic pressure distribution around industrial sound sources is necessary for determination of the parameters of such models. In order to satisfy requirements, the distribution of acoustic pressure amplitudes as well as the distribution of phase shift angles between acoustic signals are to be determined. The presented investigations constitute a part of the research program related to the application of inversion methods in the assessment of acoustic parameters of machines operating under industrial conditions, as well as to the comparative analysis of the hereby obtained results with the results obtainable by other methods of testing.

**Keywords:** industrial noise, acoustic field, sound power.

## 1. Introduction

Inversion methods can be applied in investigations of acoustic parameters of machines operating under industrial conditions [2, 3, 5]. They allow to perform the acoustic assessment of machines on the basis of analysis of acoustic field parameters [1, 6, 7]. Those methods are related to modelling of the process of a vibroacoustic energy radiation from the source to the observation point. The determined values of acoustic field parameters in receiving points allow to reverse the modelled propagation path and the estimation of the sound source parameters. The development of inversion methods combined with other computer methods such as Finite and Boundary Element Methods as well as geometric methods of estimation of the acoustic signals propagation inside rooms, allows to

localise more effectively the complex sound sources. The reconstruction of sound sources by means of the Boundary Element Method (BEM) and the inversion methods, constitutes an important tool for identification of a sound source of any shape. One of the most important advantages of those methods is the possibility of localising machine body elements and functional kinematics' pairs of an excessive vibroactivity.

## 2. Investigation method

The inversion method is based on the substitution of the actual sound source by the system of substitute sources. Then, certain parameters of those sources are simulated, in order to obtain the sound field distribution generated by the system of substitute sources, being as much as possible corresponding to the acoustic field distribution around the actual source. Inversion methods can be applied for identification of vibroacoustic energy sources, in problems of a sound radiation inversion by vibrating surfaces as well as in acoustic assessments of machines, performed on the basis of the analysis of sound field parameters.

The acoustic pressure value in the observation point  $p_j$  results from the assumed calculation model [2, 9]:

$$p_j^2 = \sum_{i=1}^I H_{ij} \cdot N_i \quad [\text{Pa}^2], \quad (1)$$

where  $N_i$  – sound power of the  $i$ -th source,  $H_{ij}$  – value of the transfer function between the acoustic power value of the  $i$ -th source and the acoustic pressure value in the  $j$ -th point.

If we write Eq. (1) in the matrix notation:

$$\mathbf{p}^2 = \mathbf{H} \cdot \mathbf{N} \quad (2)$$

and take into account, that in the observation point we actually measure the emission pressure and the background noise, the Eq. (2) takes the form:

$$\mathbf{p}^2 = \mathbf{H} \cdot \mathbf{N} + \mathbf{e}, \quad (3)$$

where  $\mathbf{e} = p_e^2 - p_m^2$  – error vector, difference between the pressure estimated from the noise propagation model ( $p_e$ ) and the value measured in the observation point ( $p_m$ ).

Searching for a solution is based on the assumption that we know the location of  $I$  sound sources of the machine under testing and measure the acoustic pressure in the finite number  $J$  of observation points. In order to limit the error vector we optimise the parameters of individual sources in the model. The methods of the shortest distances, the least squares or the Singular Value Decomposition (SVD) are usually applied [3, 4, 8]. The least square method was used in calculations of acoustic powers.

### 2.1. Measurement of sound pressure distribution

Tests were performed in the room of perpendicular walls of dimensions: 6.5 m  $\times$  4 m  $\times$  3.0 m. Three walls (2 shorter and 1 longer) were lined with a mineral wool covered by a felted fabric, while the fourth wall was made of polycarbonate plates. The ceiling was finished with a special material of sound-absorbing properties. The floor was covered with terracotta plates. The mechanical press was placed on a special vibroinsulated foundation. Several relevant anti-noise protections were attached to the press body. Measurements were made for the following operations of the press: hand and automatic feed in a continuous mode at cutting washers of a diameter of 40 mm from the steel sheet strip (2 mm thick and 47 mm wide).

The equipment of the National Instruments Company with the NI PXI-1042Q basic module was used. Two measuring cards of the NI PXI-4472B type – allowing simultaneous 16-channel recording of data – were installed in the module.

Acoustic pressure was measured by twelve measuring microphones 40PQ of the G.R.A.S. Company, placed at distances of 1 m to 1.5 m from the press at various heights above the floor. Coordinates of microphone positions are given in Table 1 and in Fig. 1. The signal, averaged for the duration time of cutting washers from one flat bar (approximately 10 s), was recorded in frequency bands of a constant width of 10 Hz in the range from 0 Hz to 12600 Hz.

**Table 1.** Coordinates of microphone positions

Measuring microphone No	Coordinates of the measuring microphone [cm]		
	$x$	$y$	$z$
M1	-30	121	157.5
M2	-60.5	61	94.5
M3	-60.5	0	164
M4	-30	-60.5	116.5
M5	0	-91	151
M6	30	37	267.5
M7	61	152	110
M8	152	91	156
M9	182	0	47.5
M10	151.5	-60.5	126
M11	122	-90.5	179.5
M12	122	-121	80.5

Utilising simultaneous measurements of acoustic signals, the phase shift angles between the sound pressure measured by M1 microphone and the remaining 11 measuring microphones were determined.

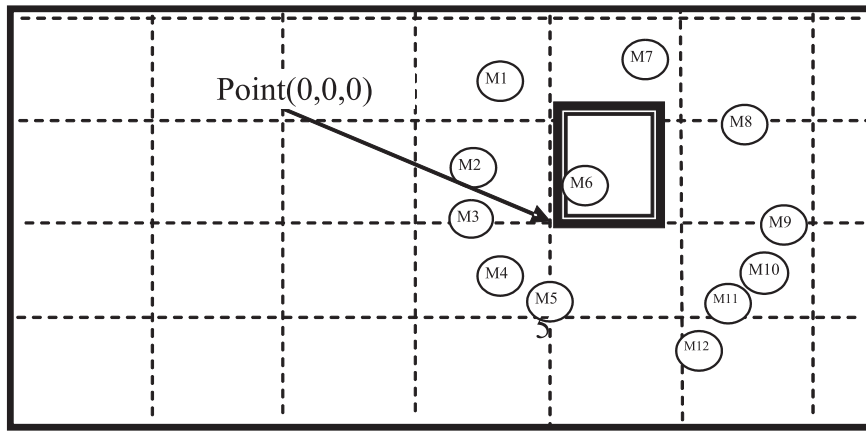

Fig. 1. Schematic presentation of the measuring points placement around the KD2122 press.

The amplitude of the acoustic pressure was determined from the power spectral density of signals from measuring microphones M1–M12 (Fig. 2).

$$\overline{p^2} = G_{xx}, \quad (4)$$

where

$$G_{xx} = \int_{f-\frac{1}{2}\Delta f}^{f+\frac{1}{2}\Delta f} G_{xx}(f) df \quad [\text{N}^2/\text{m}^4];$$

$G_{xx}(f)$  – power spectral density function,  $f$  – tested frequency [Hz],  $\Delta f$  – frequency band width [Hz].

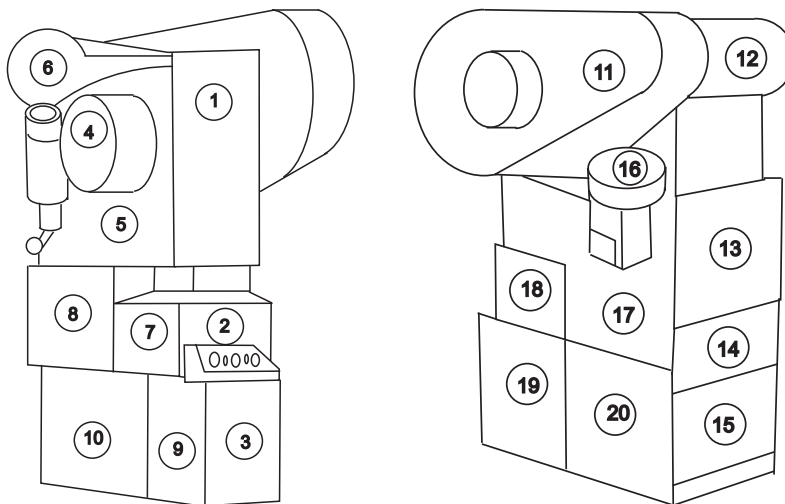

Fig. 2. Schematic presentation of the partition of the press body surface.

Phase shift angle  $\psi_m$  between the M1-th microphone and the  $x$ -th microphone was determined from the ratio of the imaginary part to the real one, of the cross spectral density function  $G_{1x}$ :

$$\Psi_x = \arctan \left( \frac{\text{Im}(G_{1x})}{\text{Re}(G_{1x})} \right), \quad x \neq 1, \quad (5)$$

where

$$G_{1x} = \int_{f-\frac{1}{2}\Delta f}^{f+\frac{1}{2}\Delta f} G_{1x}(f) \, df,$$

$G_{1x}$  – cross spectral density function.

The surface area of the press body was divided into 9 segments corresponding to the main sources of vibroacoustic energy radiated by the machine surface (Fig. 3, Table 2). This was done for the calculation purpose and for the estimation of the transfer function between elements of the press body (noise sources) and the acoustic pressure level in the observation points. Markings of the partitions are as follows: lower body (LB), screen of the footing (SF), left side screen (ISS), right side screen (rSS), tool housing (TH), front plate (FP), left upper body (lUB), right upper body (rUB), back wall (BW).

**Table 2.**

Body segment (marking)	Elements of the press KD2212 body – division								
	Front plate (FP)	Screen of the footing (SF)	Left side screen (ISS)	Right side screen (rSS)	Tool housing (TH)	Lower body (LB)	Left upper body (lUB)	Right upper body (rUB)	Back wall (BW)
Surface No	<b>1</b>	<b>3 9 19</b>	<b>8</b>	<b>17</b>	<b>2 7 18</b>	<b>10 15 20</b>	<b>4 5 6</b>	<b>11 16</b>	<b>12 13 14</b>

The assumption of such partition of the body surface area follows from the previous reciprocity measurements. Additionally this arrangement was providing the possibility of comparing the vibroacoustic activity of those areas determined by the reciprocity method and by inversion.

### 3. Results

Analysis of the measurement results and the determination of acoustic powers of the substitute sound sources was done in the frequency bands of a constant width  $\Delta f = 10$  Hz, in the range from 100 to 12500 Hz as well as in one-third-octave bands within mid-band frequency from 100 to 12500 Hz. The calculation results are presented in Fig. 3 – spectra of sound powers of individual segments of the press – and in Fig. 4 – spectra in one-third-octave bands.

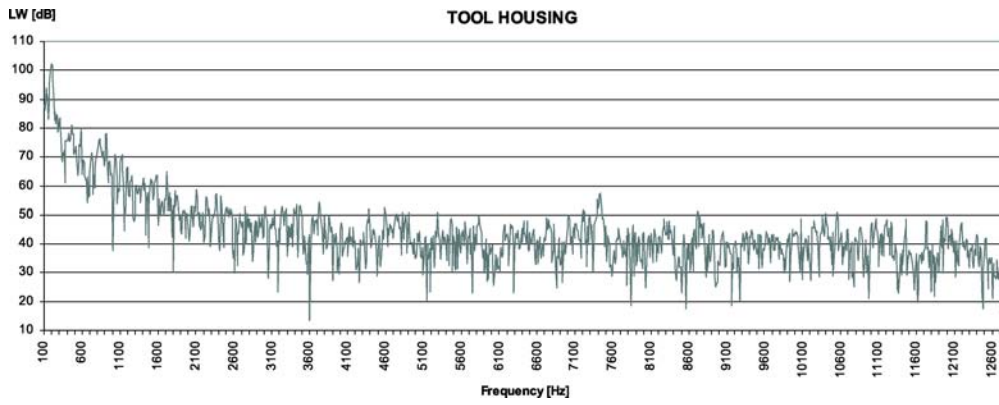

Fig. 3. Power spectrum of the acoustic power of partial noise sources of the mechanical press.

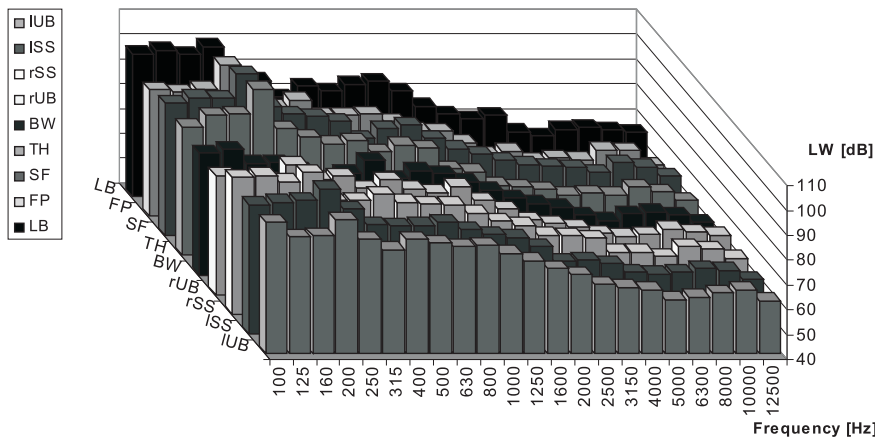

Fig. 4. Acoustic powers of partial noise sources of the mechanical press in one-third-octave bands.

Figure 5 presents the comparison of the total acoustic power of the mechanical press calculated by three different methods: inversion, reciprocity and survey in-

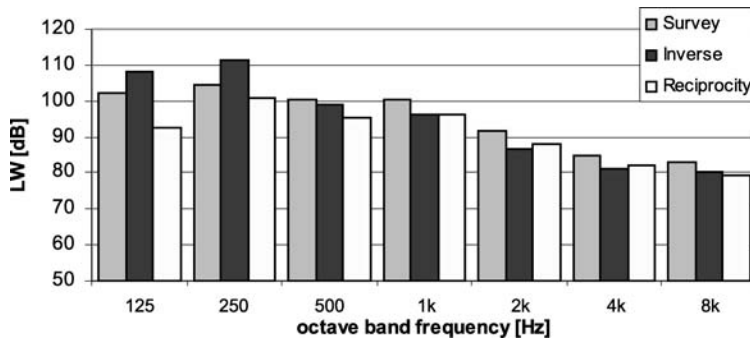

Fig. 5. Comparison of acoustic power levels of the mechanical press calculated by three different methods: inversion, reciprocity and survey.

situ, for the same mode of operation of the machine. The comparison of spectra of the selected areas of the press is given in Fig. 6. The presented spectra indicate distinct differences in the acoustic power values – especially in lower frequencies. However, extraordinary compatibility occurs at assessment of the correlated value of the sound power level, LNA.

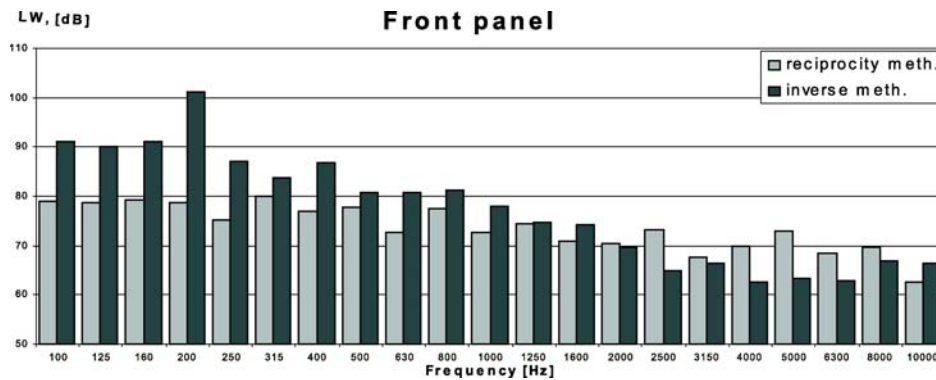

Fig. 6. Comparison of one-third-octave spectra of acoustic powers of the selected areas of the press body.

#### 4. Conclusions

Inversion methods can be applied in investigations of acoustic parameters of machines operating under industrial conditions. The methods allow to perform the acoustic assessment of machines on the basis of analysis of the acoustic field parameters. In the experiment presented hereby, the measurements of the acoustic pressure were done simultaneously in 12 measuring points. The mechanical press was modelled by 9 noise sources placed on the body surface of the machine. The acoustic power of partial sound sources on the machine body (when taking into consideration the mutual configuration of the substitute sources and the observation points) was determined.

The obtained results of the acoustic power for individual segments of the press surface were compared with the relevant measurements performed by the reciprocity method. Distinct differences in the acoustic power levels determined by both methods occur in lower frequencies. The comparison of the total sound power of the mechanical press calculated by three methods: inversion, reciprocity and survey, indicates a good compatibility of the correlated value of A-weighted sound power level and a relatively good compatibility in octave frequency bands.

#### Acknowledgments

The presented theoretical and experimental investigations were performed within the Research Project N N504 342536 of the Department of Mechanics and Vibroacoustics of the University of Science and Technology (AGH).

### References

- [1] BATKO W., DĄBROWSKI Z., ENGEL Z., KICIŃSKI J., WEYNA S., *New scientific research to examine vibro-acoustic process* [in Polish], Edited by ITE-PIB, 2005.
- [2] ENGEL Z., PIECHOWICZ J., STRYCNIEWICZ L., *The fundamentals of industrial vibroacoustics* [in Polish], Edited by WIMIR AGH, Kraków 2003.
- [3] ENGEL Z., STRYCNIEWICZ L., *Acoustic Modeling of Machines*, Archives of Acoustics, **24**, 4, 413–424 (1999).
- [4] ENGEL Z., STRYCNIEWICZ L., PIECHOWICZ J., *Application of the inversion method for the determination of partial acoustic powers of machines* [in Polish], Proc. L OSA, Szczyrk–Gliwice, 2003, p. 70–73.
- [5] ENGEL Z., STRYCNIEWICZ L., PIECHOWICZ J., *Application of the inversion method for the determination of sound parameters of machines in industrial room* [in Polish], Proc. XXXII Zimowej Szkoły Zwalczenia Zagrożeń Wibroakustycznych, Gliwice–Szczyrk 9–13.02.2004, p. 9–14.
- [6] PIECHOWICZ J., *Determination of acoustic fields in industrial room*, Archives of Acoustics, **32**, 2, 313–319 (2007).
- [7] PIECHOWICZ J., *Acoustic field in the mechanical workshop*, Archives of Acoustics, **32**, 4, 221–226 (2007).
- [8] PIECHOWICZ J., *Regularisation problems at the determination of the acoustic power of sound sources*, Archives of Acoustics, **31**, 4, 287–294 (2006).
- [9] STRYCNIEWICZ L., *Identification of zones of increased vibroacoustic emission by means of the inverse method*, Archives of Acoustics, **29**, 4, 563–576 (2004).